

FOR SUBDUED INSIGNIA

ACU:

YELLOW AND WHITE AREAS TO BE BLACK 67138.
 RED AND BLUE AREAS TO BE FOLIAGE GREEN 67202.

REVISIONS

LTR	DESCRIPTION	DATE	APPROVED
B	STITCH COUNT INFORMATION ADDED.	27 JAN 2012	<i>pm SAO</i> <i>Charles V. Mugno</i> CHARLES V. MUGNO DIRECTOR

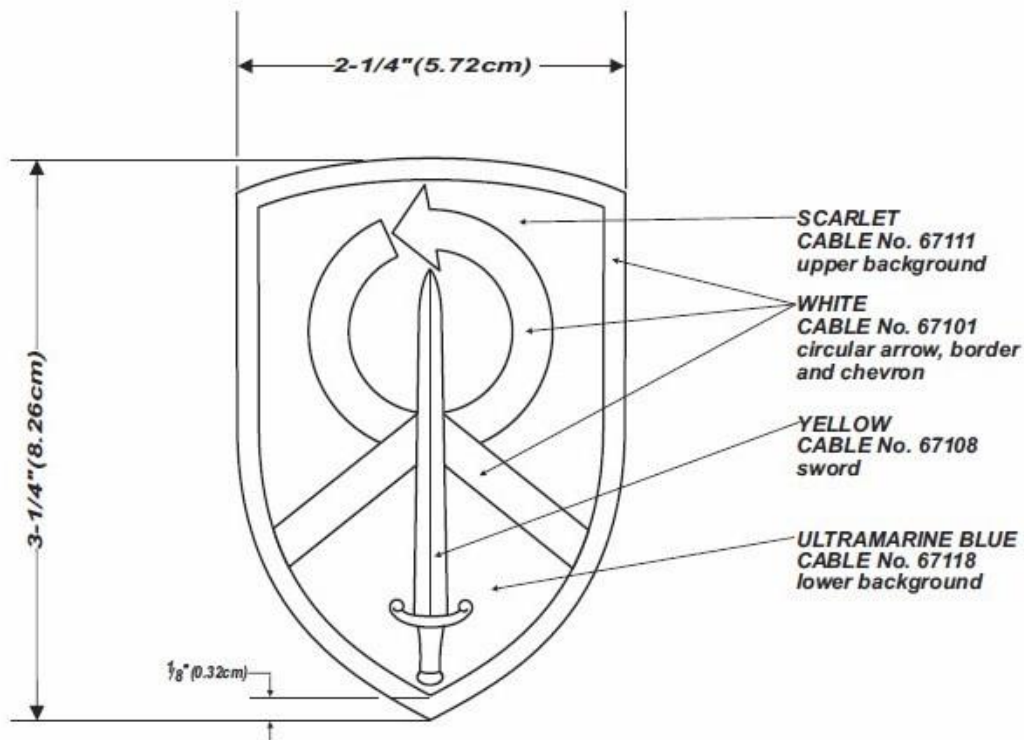

DESIGNED FOR OVEREDGE STITCHING

STITCH COUNT

6400 STITCHES (minimum)
90/2 DENIER
12/4 SPAN

UNLESS OTHERWISE SPECIFIED DIMENSIONS ARE IN INCHES
 TOLERANCES ON FRACTIONS DECIMALS ANGLES

MATERIALS:
 TO BE MANUFACTURED IN ACCORDANCE WITH MIL-DTL-14652

EXAMINED	SAO
CHECKED	pm
PREPARED	CA
APPROVED	<i>Charles V. Mugno</i> CHARLES V. MUGNO DIRECTOR

THE INSTITUTE OF HERALDRY, DEPARTMENT OF THE ARMY
 9325 GUNSTON RD. S-110 FORT BELVOIR, VA 22060-5579

SHOULDER SLEEVE INSIGNIA
451ST SUSTAINMENT COMMAND
UNITED STATES ARMY RESERVE

SIZE	CONTROL IDENT. NO	A - 1 - 1065
A	22571	
SCALE	FULL	DATE
		20 OCTOBER 2011